

PAVEMENT REINFORCEMENT SYSTEMS

SYSTEM OVERVIEW



› The GlasGrid® System extends pavement life thus reducing maintenance and life cycle costs.

Today's Most Advanced Pavement Rehabilitation System

Fatigue and reflective cracking in pavements is typically caused by traffic loading, age hardening or temperature cycling. When cracking is present, the traditional remedy has been to apply thicker asphalt overlays. For each inch of applied overlay, existing reflective cracks are generally deterred from reaching the surface for a period of one year.

THE GLASGRID® SYSTEM EXTENDS PAVEMENT LIFE BY UP TO 200%

The GlasGrid® Pavement Reinforcement System provides additional support to resist the migration of reflective cracks in roadway applications. Manufactured by Saint-Gobain ADFORS in Albion, New York, this interlayer system is composed of a series of fiberglass strands coated with an elastomeric polymer and formed into a grid structure. Each strand has a remarkably high tensile strength and high modulus of elasticity; this is particularly important as asphalt concrete typically cracks at low strains. This combination makes the GlasGrid System stronger than steel, pound for pound.

When the GlasGrid System is “sandwiched” between the leveling and surface course asphalt in a conventional asphalt overlay, it becomes the hidden strength in the road – designed to turn vertical crack stresses horizontally and effectively dissipate them.

EASILY INSTALLED AND UP TO THE TASK

The GlasGrid System is easily installed without specialized equipment or labor. With its pressure-activated adhesive, it's considered to be the most expedient interlayer system relative to installation time. The GlasGrid System has proven to be effective in every geographical area and climate – from desert environments to near-arctic conditions.

HIGHLY MILLABLE

In contrast with other interlayer systems, the GlasGrid System is easily broken up by traditional milling equipment. It also has an additional benefit: its main component is silica, a natural substance that is environmentally friendly.





How the GlasGrid® System Reinforces a Pavement

When conventional rehabilitation procedures are used, an asphalt overlay is placed over the existing rigid or flexible pavement. This provides some additional road life, but the existing reflective cracks continue to propagate prematurely toward the surface, as shown in Figure 1.

When used to reinforce asphalt concrete, the GlasGrid® System helps to create a composite material combining the compressive strength of the asphalt mix with the tensile strength of glass fibers. By introducing a stiff tensile element at the base of an overlay, cracks propagating toward the surface are intercepted and prevented from immediately migrating further. Instead, the crack is redirected horizontally, as shown in Figure 2.

This process works best when “through-hole bonding” takes place between the asphalt layers. As the term suggests, this involves the development of a strong bond between the overlay and the underlying level-up asphalt layer. This can be achieved only when an open aperture grid structure is used for reinforcement. The GlasGrid reinforced overlay will itself start to crack in time, but at a much reduced rate, thereby significantly extending the life of the road.

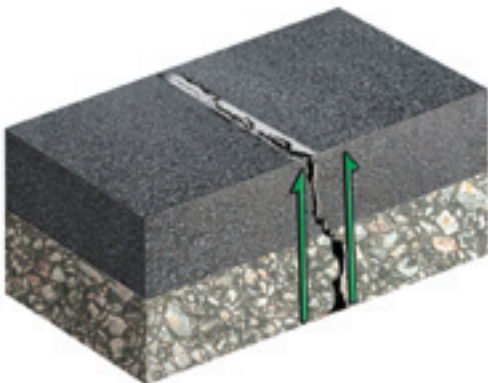

FIGURE 1: Cracks migrate toward surface in unreinforced overlay.

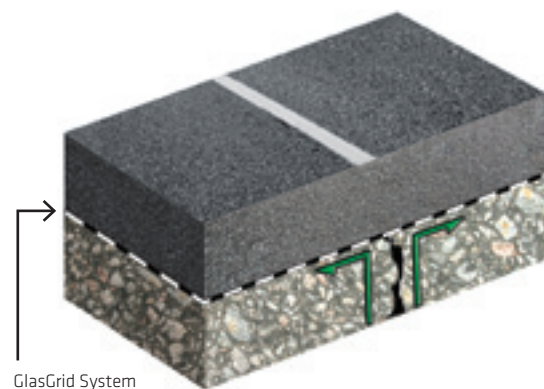

FIGURE 2: Cracks are redirected in GlasGrid reinforced overlay.

► The GlasGrid® System's open grid structure promotes the efficient transfer of stress from both overlying and underlying asphalt layers.



GlasGrid® System's Performance Exceeds Other Interlayers

Engineers today can choose from several interlayer systems. These systems are made from various asphalt binders in combination with sand and/or aggregate, or from one or more geosynthetics, which may also be combined with binders.

Bituminous-based interlayer systems such as slurries and seals provide effective waterproofing but even with the advancement in modified binders, they offer limited crack mitigation benefits. Over the last 30 years, geosynthetic interlayers have proven to be worthy alternatives with their added stiffness, uniform quality and widespread availability.

As depicted in Figure 3, a number of criteria can be used to determine the suitability of a specific interlayer product. Researchers have found that the performance of a geosynthetic interlayer system can be predicted based on the key material properties structure and strength.

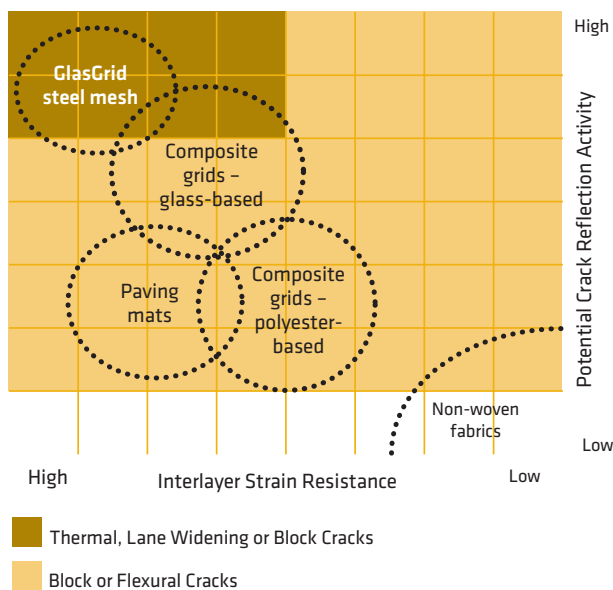

FIGURE 3: Suitability of interlayer products for medium to high traffic conditions.

STRUCTURE

The interlayer system is defined as being either open (GlasGrid® System and steel mesh systems) or closed (composite grids and paving fabrics). An open grid structure promotes “through-hole bonding” (Figure 4) and more efficient stress transfer to the grid by both the overlying and underlying aggregate matrices of the asphalt layers. This is particularly important to prevent the propagation of active cracks within the pavement. By contrast, the transfer of crack stresses in fabric-based interlayer systems takes place through the relatively weak bond formed between the asphalt binder and the fabric.

STRENGTH

Only GlasGrid Mesh and steel mesh systems have sufficient tensile strength at strains less than 3% to deter the propagation of cracks caused by traffic loading or thermal movement.

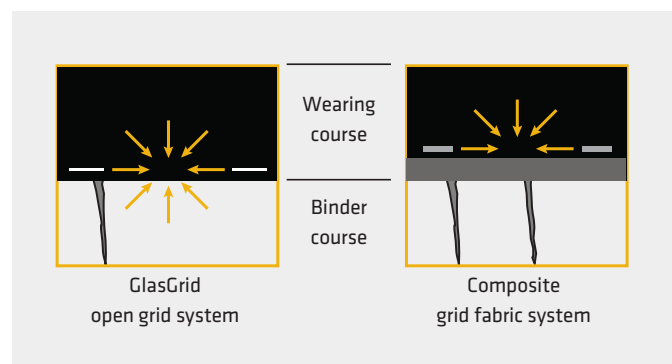

FIGURE 4: Through-hole bonding occurs between the ribs in the open grid structure of the GlasGrid System.



CREEP

Long-term creep strength is required to restrain the propagation of cracks associated with thermal movement or lane widening. The GlasGrid® System and steel mesh are the only grids that possess sufficient creep characteristics to resist a high level of sustained stress over long periods of time.

EASE OF INSTALLATION

With its pressure-activated adhesive, the GlasGrid System is the fastest installed interlayer on the market. As much as 25,000 square yards of grid can be installed in one day using a standard laydown unit. In addition, the installation of the GlasGrid System can be easily adapted to local weather conditions or unique construction requirements.

MILLABILITY AND RECYCLABILITY

With the exception of steel grids in thin asphalt overlays, most geosynthetic interlayer systems are millable using conventional reclaiming equipment. However, when it comes to recycling reinforced asphalt, only pavements reinforced with the GlasGrid System can typically be ground up and reused in other road projects as a recycled asphalt pavement, or RAP (Image A).

PROVEN PERFORMANCE

Although advancements have been made to the coating and adhesive, the GlasGrid System is still manufactured as it was originally more than 20 years ago. This is testament to the product's extensive and proven success on project sites throughout the world.



IMAGE A: Milled asphalt containing GlasGrid product can be easily recycled for use on other projects.

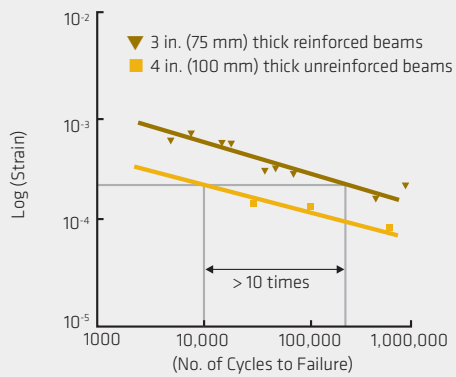

FIGURE 5: Simple Beam Test Results for a GlasGrid reinforced 3-in. thick beam vs. a 4-in. thick unreinforced beam.

Research Quantifies the Benefits of the GlasGrid® System

The use of interlayers for reflective cracking has been extensively researched over the last 30 years. In particular, three key research projects have quantified the benefits of using GlasGrid and help define its areas of application.

TEXAS A&M UNIVERSITY

Studies using the Overlay Test (Figure 6) and the Beam Fatigue Test (Figure 7) on reinforced asphalt beams demonstrated a two- to three-fold improvement in the life of a GlasGrid reinforced overlay compared with an overlay constructed using the same thickness of unreinforced asphalt. These two test methods are still used widely to evaluate the performance of asphalt mixes and interlayer systems.

A sub-study was also conducted to compare the performance of a thinner reinforced section to a thicker unreinforced section. These results are presented in Figure 5. These results show at least a 10-fold increase in the life of the thinner, reinforced asphalt.

In addition to the main laboratory testing undertaken at Texas A&M University, a performance prediction model was developed using the test data. Using traffic, temperature and pavement geometry variables, comparisons were made of the predicted performance for unreinforced and GlasGrid reinforced overlays. For the example shown in Figure 8, the predicted performance benefit of the 100 kN GlasGrid reinforced overlay is 1.5 to 2 times that for the unreinforced overlay. The performance of a 200 kN product (GlasGrid® 8502 or 8512) is expected to be double that of the 100 kN grid.

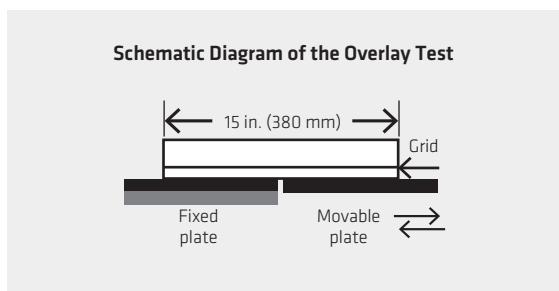

FIGURE 6

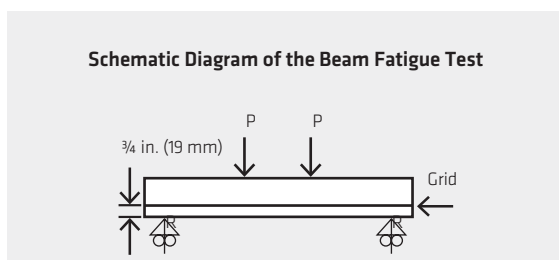

FIGURE 7

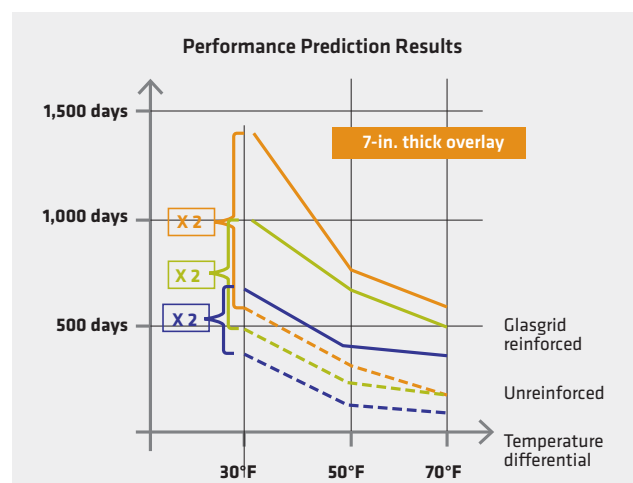

FIGURE 8

Products	Interface Shear Stiffness (MPa/mm)	Interface Shear Strength (kPa)
Open Grid Type 1	24.7 (68%)	Not failed
Composite Grid Type 1	8.1 (22%)	240
Composite Grid Type 2	14.3 (40%)	270
GlasGrid	36.4 (100%)	Not failed
Composite Grid Type 3	14.1 (40%)	245

TABLE 1: Reported values of interface shear strength and stiffness completed at University of Nottingham, UK.

THE UNIVERSITY OF NOTTINGHAM, UK

An interface bond test (Figure 9) was used to measure the quality of the bond between various interlayers and the asphalt. The test results shown in Table 1 strongly suggest that the presence of a fabric – and not grids – results in a serious reduction in the interface shear stiffness.

Semi-continuously supported beam tests (Figure 7, on page 6), were also conducted at the University of Nottingham to determine the ability of interlayer materials to resist crack propagation in notched asphalt beams. The test simulates a stress distribution similar to that found in pavements under normal trafficking conditions.

The results shown in Table 2 on page 10 present the worst performing section (in this case the unreinforced section) and apply a “fatigue factor” to the other sections in order to represent the reduced rate of crack propagation. (i.e., the greater the fatigue factor, the lower the crack propagation rate.)

The fatigue factor and bond strength associated with a particular interlayer are key input parameters for the performance model developed. Based on the data shown, the model predicts that a GlasGrid interlayer will enhance the crack propagation resistance for an asphalt overlay by a factor of two to three times.

DELFT UNIVERSITY, THE NETHERLANDS

Following an extensive field performance evaluation study and comprehensive laboratory testing program, a performance prediction model was developed for pavement overlays subject to reflective cracking caused by thermally induced stresses. This model was subsequently used to develop the Anti-Reflective Cracking Design Software (ARCDES0) as detailed on page 9. It also demonstrated that for a range of input parameters, the design life of an asphalt overlay reinforced with the GlasGrid® 8501 product is likely to be two times that for an unreinforced overlay.

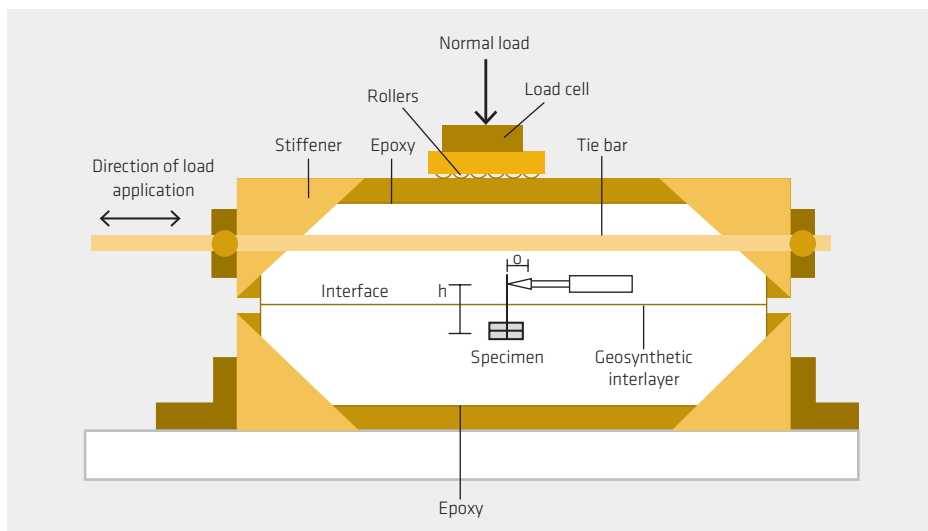

FIGURE 9: Interface bond test apparatus

IMAGE B: GlasGrid was installed at the National Center for Asphalt Technology (NCAT) pavement test track in Opelika, AL.



Research Confirms Benefits of the GlasGrid® System

NCAT TEST FACILITY, OPELIKA, ALABAMA

The National Center for Asphalt Technology (NCAT) features one of the country's largest and most advanced full-scale pavement testing facilities (Image B). During construction for the Center's inaugural test sections in 2000, GlasGrid® 8501 was included in a 100-foot long section of track. An adjacent 100 feet of unreinforced track served as a control section.

The entire track is supported by 20 in. of hot mix asphalt (HMA) base to isolate distresses to the top four inches. The Marshall SMA test mix consisted of a ¾-in. nominal maximum aggregate size, crushed granite and flyash mineral filler. A 6.2% SBR-modified PF76-22 liquid binder was specified. An emulsion tack coat of type CSS-1h was applied at a rate of 0.03 gallons per square yard before the placement of each lift of asphalt; the GlasGrid was placed after the application of the tack coat on the binder course.

Both sections were subjected to 20 million Equivalent Single Axle Loads (ESALs) of accelerated traffic loading, the equivalent of 20 years' worth of trafficking on a typical interstate highway. Following this intense trafficking, longitudinal cracking was observed throughout the length of the control section. In contrast, no cracking was observed in the GlasGrid reinforced test section. An exploratory core of the reinforced section removed after trafficking showed that the GlasGrid was still intact, bonded to both the underlying and overlying layers of asphalt (Image C).



IMAGE C: GlasGrid remains intact after 20 million ESALs of traffic loading.

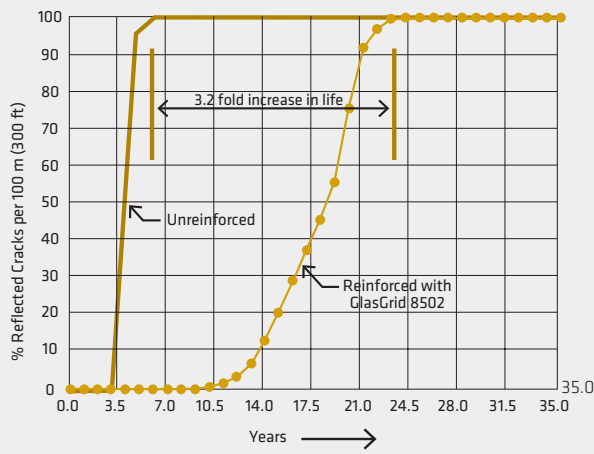

FIGURE 10: Estimated life of GlasGrid reinforced vs. unreinforced overlay for a typical composite pavement structure.

Design of Reinforced Overlays

The following software programs can be used for the design of overlays incorporating the GlasGrid® System. Tensar International Corporation (Tensar) provides analyses of asphalt overlays using these programs at no charge. For more information, check with your local Tensar representative.

OLCRACK

The OLCRACK software was developed based on the results of a study undertaken at the University of Nottingham in the UK. Designs for GlasGrid reinforced overlays on flexible pavements are based on traffic-induced stresses.

Design considerations include:

- ▶ Anticipated traffic loading (magnitude and intensity)
- ▶ Thickness and material properties of the existing pavement structure and the new asphalt overlay
- ▶ Width and spacing of cracks on the existing pavement
- ▶ Subgrade material properties

A typical set of results from the OLCRACK software is shown in Figures 11 and 12. In this example, the design life has been increased from nearly 700,000 ESALs to more than 1.6 million ESALs with GlasGrid reinforcement.

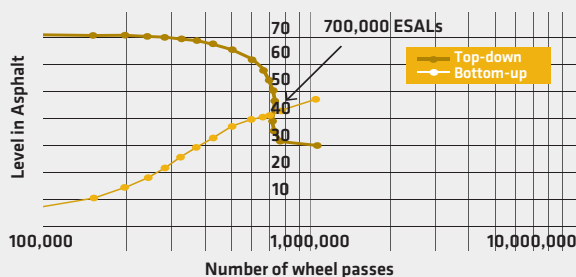

FIGURE 11: Unreinforced crack development plot.

ANTI-REFLECTIVE CRACKING DESIGN SOFTWARE (ARCDESO)

The ARCDESO software was developed based on the research undertaken at Delft University in the Netherlands. The program helps design unreinforced and GlasGrid reinforced overlays constructed on flexible, semi-rigid and rigid pavements subjected to thermally induced stresses.

Design considerations include:

- ▶ Location of the project – used to retrieve local temperature data from any recognized local or international weather database
- ▶ Anticipated maintenance strategy (e.g., tack coat and four-inch thick asphalt overlay)
- ▶ Thickness and material properties of the existing pavement structure
- ▶ Width and spacing of cracks on the existing pavement
- ▶ Subgrade material properties

Based on a discrete set of input data, the ARCDESO software predicts the crack development rate for reinforced and unreinforced overlays. A typical set of results is shown in Figure 10 (above). In this example, GlasGrid reinforcement more than triples (3x) the design life of the overlay.

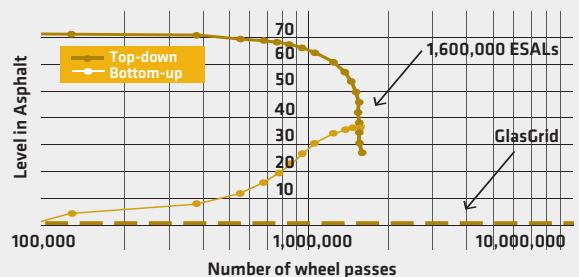

FIGURE 12: Reinforced crack development plot.



Cost Benefits of the GlasGrid® System

To determine the potential long-term cost benefits of the GlasGrid® System, it is first necessary to predict the performance of a particular overlay.

In Figure 13, the continuing deterioration of a pavement surface is indicated by a corresponding reduction in the Pavement Condition Index (PCI). In this example, a four-inch thick overlay for a high volume road has been designed to last for 10 years. If there were no reflective cracks present on the underlying pavement surface, the deterioration of the new pavement would likely continue along the solid line shown.

Unfortunately, the existing pavement surface exhibits reflective cracking. Therefore, although the four-inch thick asphalt overlay is sufficient to last for 10 years from an overall structural perspective, nearly all of the existing cracks will have propagated through the new asphalt after approximately four years; this is based on the general rule that reflective cracking propagates through an asphalt layer at a rate of one inch per year.

As significant reflective cracking begins to appear at the surface, the rate that water seeps into the pavement increases. The pavement surface is predicted to deteriorate as indicated

by Line A in Figure 13. In this example, the pavement would require a major rehabilitation after only five years as opposed to the scheduled 10 years. At this point, the owner is faced with a difficult situation and left with three principal options:

- ▶ **Scenario 1** – Undertake a full rehabilitation of the pavement by adding an additional four inches of asphalt.
- ▶ **Scenario 2** – Do nothing and tolerate a poor quality road for the remainder of its 10-year design life. At that point, the existing road will likely require an additional two inches of asphalt over and above the regular overlay thickness for the pavement. This is necessary in order to overcome structural deterioration resulting from its use while in a poor condition.
- ▶ **Scenario 3** – Close down the road for a major crack sealing operation after five years. As this is more of a “partial fix” to the problem, it is likely that an additional one-inch thickness of asphalt will be required over and above the regular overlay thickness for the pavement at the end of its design life.

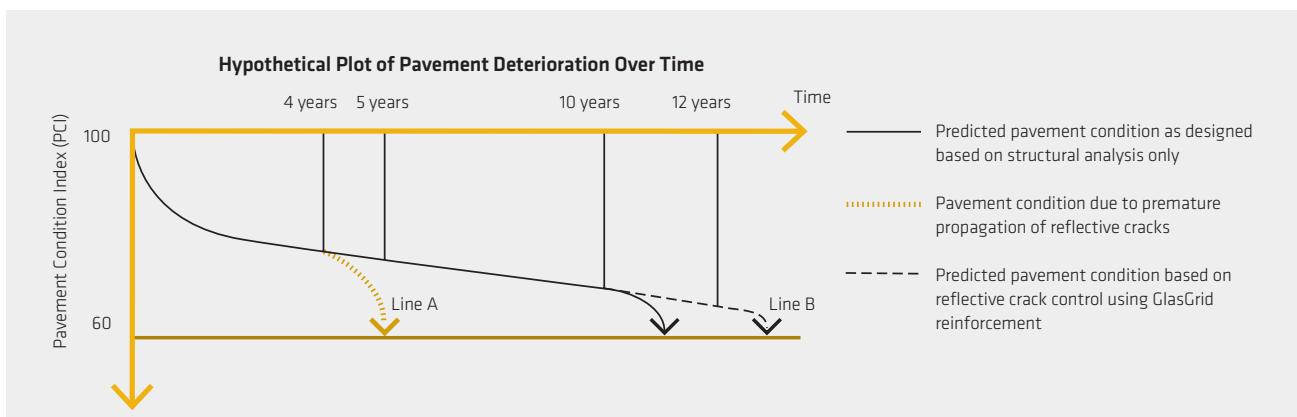

FIGURE 13



A breakdown of the typical costs associated with each of these scenario's are shown in Table 3.

- **Scenario 4** – Excluding the initial cost of the four-inch thick asphalt overlay, each of the additional costs associated with the first three scenarios can be avoided. Line B in Figure 13 illustrates that reflective cracking of the overlay is deterred until Year 12 if GlasGrid is initially used. In this example, the GlasGrid® System is predicted

to extend the crack resistance of the overlay by a factor of three, allowing the road to reach the end of its structural design life. This is described below in Tables 2 and 3.

The bottom line: there is a significant cost advantage (20–40%) in this example to using the GlasGrid System in overlays constructed over cracked pavements. These benefits will vary depending upon local design conditions and material costs.

Interlayer Type	Interface Bond Strength (MN/m ²)	Fatigue Factor (decreased rate of crack propagation)		Mechanism (above/below interface)
		Above Interface	Below Interface	
GlasGrid	10	4	4	Through-hole bonding (THB)/THB
Composite Grid	0.1	4	1	THB/Adhesion
Fabric	0.1	1	1	Adhesion/Adhesion
Unreinforced	0.1	1	1	Adhesion

TABLE 2: Input parameters used to characterize reinforcement for performance prediction.

Cost Item	Scenario 1	Scenario 2	Scenario 3	Scenario 4
Original 4 in. overlay	\$10/sq yd	\$10/sq yd	\$10/sq yd	\$10/sq yd
New 4 in. overlay after 5 years	\$10/sq yd	–	–	–
Inflation for new overlay	\$4/sq yd	–	–	–
Traffic accommodation (based on 25,000 AADT)	\$3/sq yd	–	\$3/sq yd	–
Crack sealing operation	–	–	\$3/sq yd	–
Extra thickness of AC at 10 years	–	\$5/sq yd (extra 2 in.)	\$2.50/sq yd (extra 1 in.)	–
Inflation for extra AC thickness	–	\$4/sq yd	\$2/sq yd	–
Cost of GlasGrid	–	–	–	\$5/sq yd
Total Cost	\$27/sq yd	\$19/sq yd	\$20.50/sq yd	\$15/sq yd

TABLE 3: Approximate cost of the various rehabilitation scenarios and a reinforced pavement using full-width GlasGrid 8501 and 8511 products.

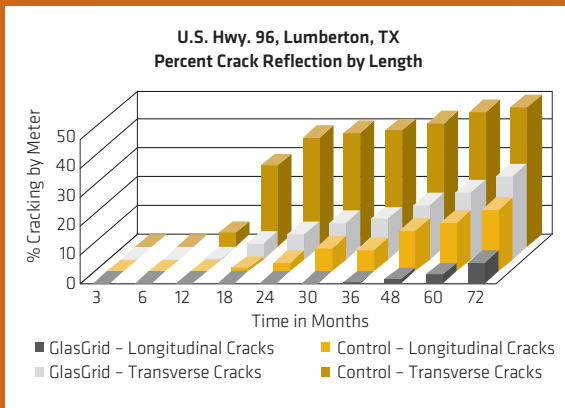

FIGURE 14

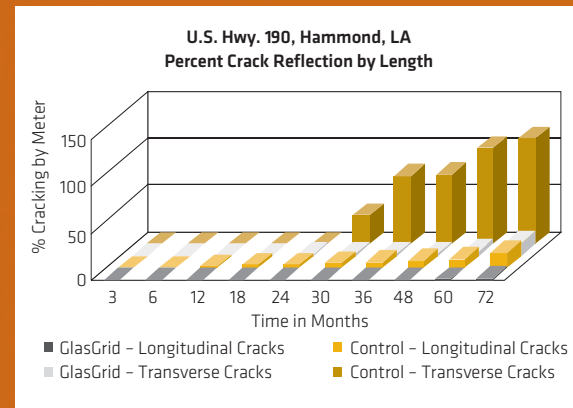

FIGURE 15

Proven Performance

Unlike most other interlayer products, the GlasGrid® System has decades of proven performance. Thousands of successful projects worldwide have utilized GlasGrid to retard the migration of reflective cracks; examples of four such projects are detailed below.

U.S. HIGHWAY 96, LUMBERTON, TEXAS

This five-lane highway is one of the main arteries of Interstate 10 and links Beaumont, Texas with several smaller cities (Image D). The road, originally constructed as a flexible pavement, is extensively trafficked by commercial vehicles and heavy trucks. In 1993, an annual average daily traffic (AADT) flow of 20,600 was recorded.

In order to reduce thermal and fatigue-related reflective cracking, the Texas Department of Transportation approved the installation of GlasGrid 8501 mesh over the entire width of a one-mile segment in the area most affected by cracking. The grid was placed on top of a 1.5-in. thick leveling course and covered with a 1.5-in. thick HMAC Type C wearing course.

At each end of the test section, control sections constructed without the GlasGrid System were monitored along with the GlasGrid Reinforced Overlays for a period of six years. The results are presented above in Figure 14. The sections of the road reinforced with the GlasGrid System show a substantial improvement with significantly fewer cracks reflected at the surface.



IMAGE D: U.S. Highway 96, Lumberton, Texas

U.S. HIGHWAY 190, HAMMOND, LOUISIANA

U.S. Highway 190 is a secondary arterial road located between Covington and Baton Rouge, Louisiana (Image E). It was originally constructed as a rigid pavement. When rehabilitation of the road took place in 1994, an AADT of 8,900 had been recorded the previous year. However, the road originally carried substantially more traffic prior to the construction of the local segment of Interstate 12. As a result, a large number of transverse and longitudinal cracks had developed in the existing full-depth asphalt and composite pavements.

The Louisiana Department of Transportation placed a 1.5-in. thick Type 8 binder course followed by a 1.5-in. thick Type 8 wearing course. GlasGrid 8501 was placed between the two courses, with one area left unreinforced to serve as a control section. The 6-year results of the monitoring undertaken post-rehabilitation are presented in Figure 15 and clearly show the benefits of using the GlasGrid System to retard reflective cracking.



IMAGE E: U.S. Highway 190, Hammond, Louisiana



STATE ROUTE 113, LORAIN COUNTY, OHIO

Located in Northeastern Ohio, Lorain County borders Cuyahoga County and is approximately 30 miles west of Cleveland (Image F). County growth, particularly in and around the community of Amherst, brought increasing traffic to local segments of State Route 113, a 60-mile east-west highway that traverses four Ohio counties. Recent measurements of AADT flow were recorded at 13,400, primarily passenger automobiles.

To accommodate the growth in traffic, the Ohio Department of Transportation (ODOT) District 3 authorized intersection lane widenings along the route. Transportation officials, who regard reflective cracking as a chief cause of pavement distress, had not been satisfied with the results from standard (unreinforced) methods of pavement widening and longitudinal joint performance. In 2003, ODOT District 3 specified the use

of GlasGrid® 8502 (or equivalent) at several designated intersections, including one near the town of Elyria. There, the GlasGrid System was placed directly over the longitudinal widening joint and topped with two asphalt layers.

While the national average for reflection of unreinforced longitudinal joints of this type is estimated to be approximately 20% a year, the longitudinal joint reinforced with the GlasGrid System reflected through at the much lower estimated rate of 3% per year. The projected joint life for the reinforced joint is 33.3 years; by contrast, the national average for similar projects with unreinforced joints is projected to be just five years. Field experience has demonstrated that the longer the joint is protected, the longer the pavement service life, with reduced life cycle costs such as crack sealing and pothole repair. (Complete detail design information is available through Tensar.)



IMAGE F: State Route 113, Lorain County, Ohio



Proven Performance

AIRPORT APPLICATIONS

The GlasGrid® Pavement Reinforcement System has been used successfully on more than 100 airport projects over the past 20 years. It has been particularly effective when installed in airport runways, taxiways and aprons where transverse thermal cracking or PCC joint cracking is prevalent on the pavement surface.

In airport applications, the GlasGrid System is typically used in one of two main ways:

- ▶ Full width repairs of aged, random block cracked or alligator cracked pavements that have not been rehabilitated for many years – GlasGrid 8501 or 8511.
- ▶ Spot repairs applied over local transverse-cracked areas – GlasGrid 8502 or 8512.

INYOKERN AIRPORT, INYOKERN, CALIFORNIA

Inyokern Airport is located in the Indian Wells Valley, 80 miles from Palmdale, CA. Three large, paved runways can accommodate almost any class of aircraft. Due to severe, sudden daily temperature cycling, thermal stresses on the airport pavements can be quite high, leading to serious

transverse cracking. Prior to undertaking rehabilitation, large (1-1.5 in. wide), closely spaced, transverse cracks were observed on the runway. It was decided that the intensity of the cracking could negatively affect aircraft maneuvers and safety.

The existing cracks on Runway 15-33 were first air-cleaned and filled with a rubberized crack sealer. A ¼-in. thick wearing course was placed on top of the GlasGrid Mesh.

A site visit on January 31, 2007, showed that following 11 years of service, the runway where the GlasGrid System was installed has resulted in only minor cracking. In contrast, an area that was left unreinforced for comparison purposes demonstrated significantly more severe cracking up to 1-in. wide.

The airport general manager, Scott Seymour, recently stated, “Prior to the rehabilitation of Runway 15-33, we were dealing with thermal transverse cracks ranging in width from 1-1.5 in. wide. The use of the GlasGrid System in the rehabilitation overlay has resulted in delaying the propagation of these cracks significantly. Our experience with the GlasGrid System has been very good and when a similar need arises in the future, we will certainly consider the use of this product again.”



IMAGE G: Inyokern Airport used the GlasGrid System to rehabilitate Runway 15-33.



GREATER ROCHESTER INTERNATIONAL AIRPORT ROCHESTER, NEW YORK

The County of Monroe operates the Greater Rochester International Airport as a medium hub for 16 air transportation providers. It handles 220 flights a day to cities in the Northeast and major hubs in the Midwest. In 1995, the airport authority began investigating options for using interlayers to improve the condition and performance of its secondary-use runway for better overall performance.

The GlasGrid® Pavement Reinforcement System was recommended as a lower cost, longer lasting alternative to a thicker asphalt overlay. Spot reinforcement of transverse cracks using the GlasGrid 8502 product would provide a strong interlayer solution capable of resisting the migration of reflective cracking.

A follow-up report from the Monroe County of Aviation indicated that the GlasGrid Pavement Reinforcement System is delivering very good performance after more than 11 years of service.

HECTOR INTERNATIONAL AIRPORT FARGO, NORTH DAKOTA

The Municipal Airport Authority operates Hector International Airport as a connecting hub for flights throughout the Midwest, West and South. In 1996, the Airport Authority investigated options for using high-strength interlayer mesh to prolong the pavement life of its main runway. Runway 13-31 is exposed to harsh conditions on a year-round basis. With the average high temperature being 82°F in July and the average high temperature being 16°F in January, wide temperature swings, severe weather conditions and heavy aircraft loadings were taking a toll on the runway.

A follow-up distress survey indicated the GlasGrid Pavement Reinforcement System is delivering very good performance after more than 10 years of service with only minor cracking in the high wheel loading areas. In contrast, the areas reinforced with paving fabric are delivering only “good” performance – even though these sections of the runway experience much less load and wear.



IMAGE H: Centralia Airport, Ontario, Canada – condition of the runway before implementing the GlasGrid System.



IMAGE I: Condition of the Centralia runway 13 years after installation of the GlasGrid System.



GlasGrid® System Applications for Reflective Cracking

The four primary types of reflective cracks are:

- ▶ Block Cracks
- ▶ Thermal Cracks
- ▶ Concrete Pavement Joint Cracks
- ▶ Lane Widening Cracks

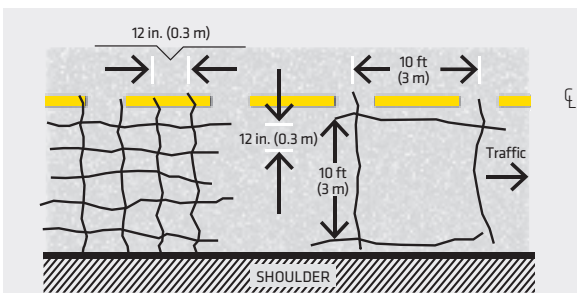

BLOCK CRACKS

PLAN VIEW

The GlasGrid System should be specified when:

- ▶ The unreinforced overlay design exceeds five years.
- ▶ The average crack width is no greater than 1 in. (25 mm).
- ▶ The block size is less than 10 ft x 10 ft (3 m x 3 m).
- ▶ The minimum block size allowed is 1 ft x 1 ft (0.3 m x 0.3 m).

NOTE: Rate crack at highest severity level present for 10% or more of total crack length.

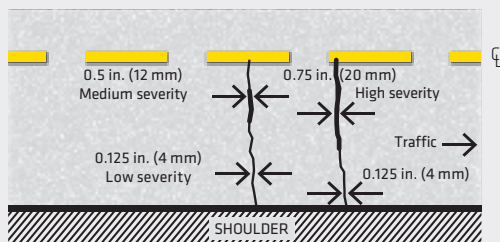

PLAN VIEW

THERMAL CRACKS

The GlasGrid System should be specified for composite pavements when:

- ▶ The Load Transfer Efficiency (based on FWD results) exceeds 70%.
- ▶ The appropriate binder type has been selected for the project.
- ▶ The correct grid strength has been selected for the local climatic conditions.

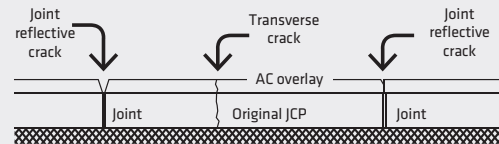

CROSS SECTION

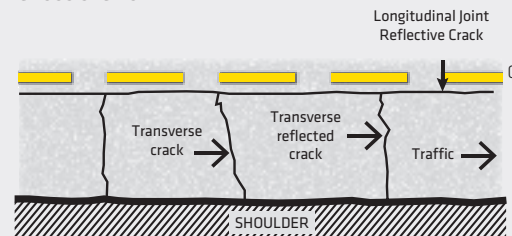

PLAN VIEW

CONCRETE PAVEMENT JOINT CRACKS

The GlasGrid System should be specified when:

- ▶ The Load Transfer Efficiency (base on FWD results) exceeds 70%.
- ▶ The thermal cracking criteria are satisfied.

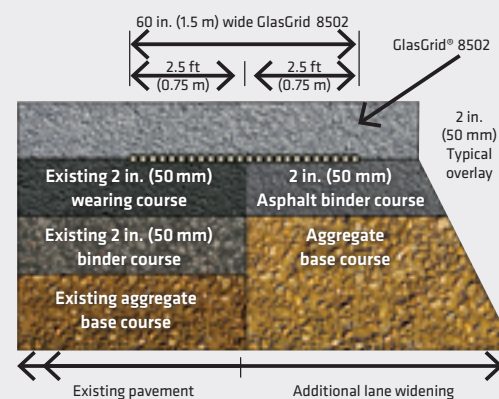

LANE WIDENING CRACKS

The GlasGrid System should be specified when:

- ▶ The crack does not fall within the wheel path.
- ▶ A level-up asphalt course should be specified when:
 - The subgrade t_{90} (time to achieve 90% consolidation) exceeds six months.
 - The new profile differs from the existing (i.e., flexible vs. rigid).



Product Application Guide

The GlasGrid® System features a variety of products that ensure optimum reinforcement benefits as the product is matched to the specific needs and material characteristics of a project. The most important considerations when selecting a product are:

- ▶ **Aperture Size** – Needs to be matched to the grading of the asphalt being reinforced. For asphalt mixes with a maximum particle size less than $\frac{3}{4}$ -in., a product with a standard sized aperture is appropriate. For coarser mixes, a larger aperture grid should be used. The aperture size may also be selected based on local environmental conditions, mix stability, past performance or user preference.
- ▶ **Tensile Strength** – The required tensile strength of a pavement reinforcement grid is essentially determined by the magnitude and activity of the existing cracks and the traffic volume likely to be encountered. The greater the amount of cracking or trafficking, the greater the required tensile strength.
- ▶ **Grid Coverage** – The amount of grid coverage required is determined by the type of crack pattern to be treated. For discrete cracks such as those associated with construction joints, it is possible to adopt a limited-coverage approach. For areas that have or are likely to experience widespread

cracking, full-width and length coverage of the road surface is typically recommended. The minimum thickness of the asphalt overlay should be 1.5-in.

- ▶ **Moisture Barrier** – Some pavement engineers maintain that significant long-term benefits are obtained by providing a moisture barrier as well as asphalt reinforcement. GlasGrid CG products help provide a barrier by incorporating a lightweight, polypropylene fabric on the back of the main grid component. Upon placement, the tack coat seeps into the fabric, forming a moisture barrier.

In most circumstances, a good quality moisture barrier can also be produced using an open grid product. In this case, the tack coat used routinely as part of the normal installation procedure acts as an efficient moisture barrier. Open aperture products also facilitate “through-hole bonding” and therefore provide a more effective means of reinforcing an asphalt overlay. Consequently, although individual pavement engineers may prefer to use a composite grid (incorporating a grid and a fabric), generally speaking, an open grid product has proven to yield significantly greater performance benefits. Table 4 on page 18 highlights the features and general uses of various GlasGrid System products. Table 5 details their specific applications.

This chart outlines the main distinguishing features of the various GlasGrid® System products along with the specific applications for which they are intended to be used.

Suggested Product Application									
GlasGrid Product	Aperture Dimensions, in. (mm)	Tensile Strength, Across Width x Along Length lbs/in. (kN/m)	Installation		Grid Coverage		Asphalt Grading		Moisture barrier is the primary function or pavement is water sensitive
			Bonded to road by self-adhesive backing on the grid	Tack coat required to bond road with the fabric backing on the grid	Full-width coverage for treatment of generally cracked road surface	Discreet coverage for treatment of specific cracks	Less than ¾ in. (19 mm)	Greater than or equal to ¾ in. (19 mm)	
8501	0.5 x 0.5 (12.5 x 12.5)	560 x 560 (100 x 100)	●		●		●		
8502	0.5 x 0.5 (12.5 x 12.5)	1,120 x 560 (200 x 100)	●			●	●		
8511	1.0 x 1.0 (25 x 25)	560 x 560 (100 x 100)	●		●		▲	●	
8512	1.0 x .75 (25 x 19)	1,120 x 560 (200 x 100)	●			●	▲	●	
8550	1.0 x 1.0 (25 x 25)	280 x 280 (50 x 50)	●		●		▲	●	
CG50	1.0 x 1.0 (25 x 25)	280 x 280 (50 x 50)		●	●		▲	●	●
CG100	1.0 x 1.0 (25 x 25)	560 x 560 (100 x 100)		●	●		▲	●	●

TABLE 4: Product Features and General Uses of GlasGrid® System

- ▲ Based on environmental conditions, mix stability or past performance
- Applicable under normal conditions

Primary/Critical Crack Type (Notes)								
Road Type	Traffic (AADT)	Thermal (1,2,3,4,5,6)	PCC Joints (3,4,5,6)	Block (5,7,11)	Lane Widening (1,7,8,9)	Alligator (7,10,11,12)	CTB Shrinkage (1,5,7)	Moisture Sensitive Pavement
Residential or parking area	<300	8501/8511 or 8502/8512	8550	8550	8501/8511 or 8502/8512	8550	8550	CG50
Residential or serviced roads	<625	8501/8511 or 8502/8512	8501/8511	8501/8511	8501/8511 or 8502/8512	8501/8511	8550	CG50
Collector/regional	<750	8501/8511 or 8502/8512	8501/8511 or 8502/8512	8501/8511	8501/8511 or 8502/8512	8501/8511	8501/8511	CG100
Inter urban/SH/SR	750 to 12,500	8501/8511 or 8502/8512	8501/8511 or 8502/8512	8501/8511 or 8502/8512	8501/8511 or 8502/8512	8501/8511	8501/8511	CG100
Interstate	>5,000	8501/8511 or 8502/8512	8501/8511 or 8502/8512	8501/8511 or 8502/8512	8501/8511 or 8502/8512	8501/8511	8501/8511	CG100

TABLE 5: Applications for the GlasGrid System

LEGEND:

- (1) Fabrics cannot be used for these applications
- (2) PCC joints must also be evaluated – see (4)
- (3) Crack sealing is recommended or mix ALD < crack width
- (4) Load Transfer Efficiency must be greater than 70%, or ensure that slab lengths are less than 20 feet.
- (5) Effective for crack widths less than one inch.
- (6) Interlayers not recommended for faulting joints
- (7) Unreinforced overlay life must exceed five (5) years
- (8) Ideally locate the LWJ outside the wheel path
- (9) In poor subgrade zones, only low creep geogrids may be used
- (10) Ensure that alligator blocks are stable under foot
- (11) Potholes must be patched
- (12) Check that surface drainage is functional

AADT = Average Annual Daily Traffic
 PCC = Portland Cement Concrete
 CTB = Cement Treated Base

SR = State Road
 SH = State Highway
 LWJ = Lane Widening Joint

Complete Road System

GlasGrid® 8501 and 8511

Specifications for Use in Asphalt Reinforcement					
Property	Test Method	8501		8511	
		Metric*	Imperial**	Metric*	Imperial**
Tensile Strength					
Across Width	ASTM D 6637	100 kN/m	560 lbs/in.	100 kN/m	560 lbs/in.
Across Length		100 kN/m	560 lbs/in.	100 kN/m	560 lbs/in.
Elongation at Break	ASTM D 6637	< 3%	< 3%	< 3%	< 3%
Melting Point	ASTM D 276	> 218°C	> 425°F	> 218°C	> 425°F
Mass/Unit Area	ASTM D 5261-92	370 g/m ²	11 oz/yd ²	370 g/m ²	11 oz/yd ²
Roll Length[†]	–	100 m	327 ft	100 m	327 ft
Roll Width[†]	–	1.5 m	5 ft	1.5 m	5 ft
Roll Area[†]	–	150 m ²	180 yd ²	150 m ²	180 yd ²
Aperture Size	–	12.5 mm x 12.5 mm	0.5 in. x 0.5 in.	25 mm x 25 mm	1 in. x 1 in.
Adhesive Backing	–	Pressure Sensitive		Pressure Sensitive	
Composition	–	Custom-knitted fiberglass mesh with elastomeric polymer coating and pressure sensitive adhesive backing.			

TABLE 6

Detail Repair System

GlasGrid 8502 and 8512

Specifications for Use in Asphalt Reinforcement					
Property	Test Method	8502		8512	
		Metric*	Imperial**	Metric*	Imperial**
Tensile Strength					
Across Width	ASTM D 6637	200 kN/m	1120 lbs/in.	200 kN/m	1120 lbs/in.
Across Length		100 kN/m	560 lbs/in.	100 kN/m	560 lbs/in.
Elongation at Break	ASTM D 6637	< 3%	< 3%	< 3%	< 3%
Melting Point	ASTM D 276	> 218°C	> 425°F	> 218°C	> 425°F
Mass/Unit Area	ASTM D 5261-92	560 g/m ²	16 oz/yd ²	560 g/m ²	16 oz/yd ²
Roll Length[†]	–	60 m	197 ft	60 m	197 ft
Roll Width[†]	–	1.5 m	5 ft	1.5 m	5 ft
Roll Area[†]	–	90 m ²	108 yd ²	90 m ²	108 yd ²
Aperture Size	–	12.5 mm x 12.5 mm	0.5 in. x 0.5 in.	25 mm x 19 mm	1 in. x .75 in.
Adhesive Backing	–	Pressure Sensitive		Pressure Sensitive	
Composition	–	Custom-knitted fiberglass mesh with elastomeric polymer coating and pressure sensitive adhesive backing.			

TABLE 7

Pavement Reinforcement Mesh

GlasGrid 8550

Specifications for Use in Asphalt Reinforcement			
Property	Test Method	8550	
		Metric*	Imperial**
Tensile Strength			
Across Width	ASTM D 6637	50 kN/m	(Across width)
Across Length		50 kN/m	(Across length)
Elongation at Break	ASTM D 6637	< 3%	< 3%
Melting Point	ASTM D 276	> 218°C	> 425°F
Mass/Unit Area	ASTM D 5261-92	185 g/m ²	5.5 oz/yd ²
Roll Length[†]	–	150 m	492 ft
Roll Width[†]	–	1.5 m	5 ft
Roll Area[†]	–	225 m ²	269 yd ²
Aperture Size	–	25 mm x 25 mm	1 in. x 1 in.
Adhesive Backing	–	Pressure Sensitive	
Composition	–	Custom-knitted fiberglass mesh with elastomeric polymer coating and pressure sensitive adhesive backing.	

TABLE 8

[†]Product is sold by the roll.
*All metric values are nominal.
**All imperial values are approximate.



Installation Procedures

PAVEMENT PREPARATION

The key elements to consider when preparing a pavement for the placement of GlasGrid products are:

- ▶ The existing pavement should be clean and dry, with an even surface.
- ▶ Any cracks exceeding 0.25-in. (6 mm) in width should be sealed using an approved sealant or the appropriate leveling course mix.
- ▶ A minimum 0.75-in. (19 mm) thick asphalt concrete leveling course should be placed.
- ▶ Before laying the grid, the surface temperature should be between 40°F (5°C) and 140°F (60°C).
- ▶ Before placing GlasGrid products, the leveling course should provide sufficient adhesion to the grid. A test procedure for determining whether sufficient adhesion exists is described below.
- ▶ The minimum thickness of the wearing course should be 1.5 in.

ADHESION TEST

The following procedure can be used to determine whether sufficient adhesion exists between the GlasGrid and the underlying asphalt:

- ▶ Cut a square-shaped sample of the GlasGrid material approximately one square yard in size.
- ▶ Place the sample on the road surface to be paved.
- ▶ Apply adequate vertical pressure to fully activate the pressure sensitive adhesive e.g., by use of a rubber tired roller or by other means.
- ▶ Insert the hook of a spring balance under the center of the GlasGrid sample (Image J).
- ▶ Pull the spring balance upward until the sample starts to pull loose, and record the gauge reading.
- ▶ In the event that 20 lbs (19 kg) or more force is required to pull the sample up from the road surface, sufficient adhesion has taken place, and the paving operation can begin.
- ▶ In the event that the sample does not have sufficient adherence, identify the cleanliness or moisture issues present and resolve them before installing the rest of the GlasGrid material.

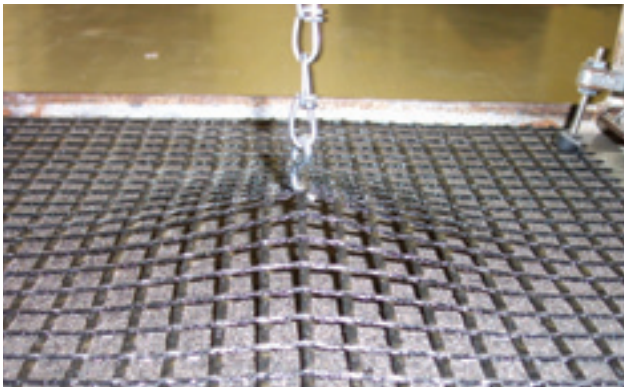

IMAGE J: Testing GlasGrid for adhesion to underlying asphalt



TACK COATS

A tack coat is a light coating of liquid asphalt applied either to an existing pavement surface or on top of the installed GlasGrid material. It is used to bond a new asphalt concrete course to the existing pavement surface.

When the GlasGrid® System was first introduced, tack coats were not universally used on new leveling courses. More recently however, the pavement industry has been implementing changes to asphalt mixes in order to make them leaner, stiffer and more rut-resistant. Consequently, these changes and the need to maximize the bond between lifts have resulted in most authorities mandating the use of a tack coat between all lifts of asphalt.

The GlasGrid System does not require a tack coat for installation. However, when a tack coat has been specified for other reasons, it should be used in accordance with the following guidelines*:

- ▶ **Type 1** – NTSS-1HM, anionic, trackless tack. The trackless tack is not sticky when cured, reducing the possibility of pickup or build-up on paving equipment.

- ▶ **Type 2** – Cationic, rapid set, CRS-2P. In general, cationic emulsions can break and set more quickly than anionic emulsions due to the electrochemical reaction between the aggregate and the binder.
- ▶ **Type 3** – Hot spray AC – AC20-5TR-PG64-XX. In general, hot spray AC tacks work well in cooler weather, when surface temperatures are at or below 80°F. When surface temperatures exceed 80°F, the manufacturer recommends that an emulsion be applied in place of the hot spray AC.

Emulsions used with the GlasGrid System must “break” and then cure before any additional asphalt is placed. Breaking is defined as the point at which the brown colored fluid turns black. Curing occurs when the residual asphalt cement contains no solvents (water or any volatiles). Reference should be made to the GlasGrid Installation Guide for additional information.

**Use of a tack coat type other than those specified above is not recommended and will require a change in the application rule, a curing time and on-site supervision by the specifying engineer.*



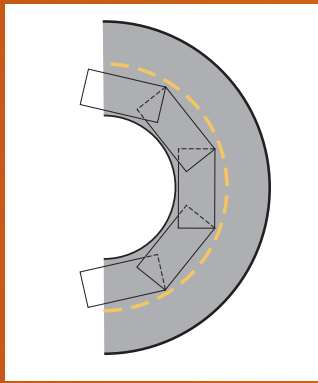

FIGURE 16: Cutting and overlapping GlasGrid around a curve

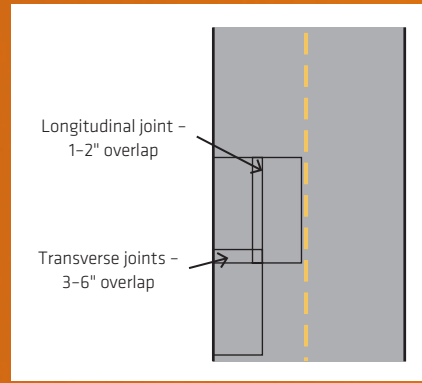

FIGURE 17: Overlapping GlasGrid across transverse or longitudinal joint

GLASGRID PLACEMENT

There are two primary ways that the GlasGrid® System can be placed on an asphalt surface. The first, and more common approach, involves mechanical placement, typically with a tractor that has been modified so that the GlasGrid material can be front-mounted (Image K). The tractor is typically used for full-width installations but can also be used for detail repairs that are sufficiently large.

An alternative installation method involves manual placement of the grid (Image L). Although the product is physically placed by hand, it is highly recommended that the GlasGrid roll be mounted on the back of a truck or other vehicle to help maintain tension during placement. Manual installation is more commonly used for localized areas of road.

Whether the GlasGrid System is placed mechanically or manually, there are several general requirements to consider:

- ▶ The grid must be installed under sufficient tension to reduce or eliminate any ripples. If ripples do occur, they must be removed prior to paving by pulling the grid tight. In some cases (e.g., on curves with tight radii), it may be necessary to cut the grid in short sections (Figure 16).

- ▶ Transverse joints should be overlapped in the direction of the paver by three to six inches (75 to 150 mm); longitudinal joints should be overlapped by one to two inches (25 to 50 mm). The overlapping of two lengths of GlasGrid is shown photographed in Image M and diagrammatically in Figure 17.
- ▶ In order to engage the pressure-activated adhesive, the surface of the grid must be rolled with a rubber-coated roller or pneumatic-tired roller. The tires must be kept clean to avoid picking up the GlasGrid material during installation.
- ▶ Construction and emergency traffic may travel over the GlasGrid material once it has been placed and rolled, but turning and/or braking must be avoided at all times. Any damaged sections caused by construction traffic must be removed and patched prior to paving. It is also important that the GlasGrid System be kept free of mud, dust and other debris during construction.

GLASGRID STORAGE

The GlasGrid System should be stored in a dry environment and must not be exposed to excessive heat, moisture or ultraviolet light. It should be kept covered and free from dust and dirt.



IMAGE K: Mechanical placement of the GlasGrid System.



IMAGE L: Manual placement of the GlasGrid System.



IMAGE M: Overlapping the GlasGrid System across transverse or longitudinal joint.



Installation Services

Installation of the GlasGrid® System is relatively simple and straightforward. However, like all construction procedures, there are advantages to using experienced personnel. This is particularly true with the GlasGrid System since time is often critical and the installation team must work quickly enough to keep ahead of the paving machine.

Most authorized distributors are equipped to provide a full installation service for the GlasGrid products they supply. Installation rates are very reasonable and since modified equipment is required for a mechanical installation procedure, contracting these services is typically the easiest and most cost-effective method for installing the GlasGrid System.

For additional information, check with your local GlasGrid Distributor.

With thousands of successful installations worldwide, the GlasGrid System can reduce maintenance costs and extend pavement life on your highway, roadway, runway or parking lot projects.

For more information on the GlasGrid Pavement Reinforcement System, please call **800-TENSAR-1**, visit www.tensarcorp.com or e-mail info@tensarcorp.com. We are happy to provide additional GlasGrid System information, complete installation guidelines, system specifications, design details, conceptual designs, preliminary cost estimates, case studies, software and much more.



GlasGrid is manufactured at an ISO 9001:2008 registered facility of Saint-Gobain ADFORS. GlasGrid is a registered trademark of Saint-Gobain ADFORS. U.S. Patent 5393559. Canadian Patent 1240873. European Patents WO 2009/021040, WO 2009/021046, WO 2009/021051. Japanese Patent 2611064. Additional patents pending. GlasPave 25 is designed to meet ASTM D7239, "Hybrid Geosynthetic Paving Mat for Highway Applications" Type 1. GlasPave 50 is designed to meet ASTM D7239, "Hybrid Geosynthetic Paving Mat for Highway Applications" Type 1.

Tensar®

Tensar International Corporation
2500 Northwinds Parkway, Suite 500
Alpharetta, Georgia 30009

800-TENSAR-1
tensarcorp.com

Distributed by:

Distributed by:

 **NILEX**
CIVIL ENVIRONMENTAL GROUP
800.667.4811 | nilex.com

Exclusive distributor in
the Americas for:



GlasGrid® is the registered trademark of Saint-Gobain ADFORS and GlasPave™ is a trademark of Saint-Gobain ADFORS. GlasGrid® and GlasPave™ are distributed in the United States of America, Canada and certain other countries by Tensar International Corporation (Tensar). Inasmuch as Saint-Gobain ADFORS and Tensar have no control over installation design, installation workmanship, accessory materials, or conditions of application, Saint-Gobain ADFORS and Tensar do not warrant the performance or results of any installation or use of GlasGrid®. This warranty disclaimer includes all implied warranties, statutory or otherwise, including the warranty of merchantability and of fitness for a particular purpose. The values and tolerances given are obtained in our laboratories and in accredited testing institutions. All imperial values are approximate. The information given in this data sheet is to the best of our knowledge true and correct. However new research and practical experience can make revisions necessary. We reserve the right to make changes at any time. Statements concerning possible use of our product are not intended as recommendations for their use in the infringement of any patent. No patent warranty of any kind, expressed or implied, is made or intended.